

TO FIT REPLACEMENT CLIP ON COPPER BERYLLIUM FINGERS

TO REMOVE DAMAGED FINGERS –

- 1. Cut aluminium extrusion at least 5 fingers away from damaged area (in both directions). Also make the cuts in line with the slots between the fingers, never through a finger. (refer to drawing 1)**
- 2. Pull extrusion off using pliers. (refer to drawing 1)**
- 3. Cut copper fingers from the door using a sharp knife. (refer to drawing 1)**
- 4. Throw away damaged fingers and aluminium extrusion. (refer to drawing 1)**

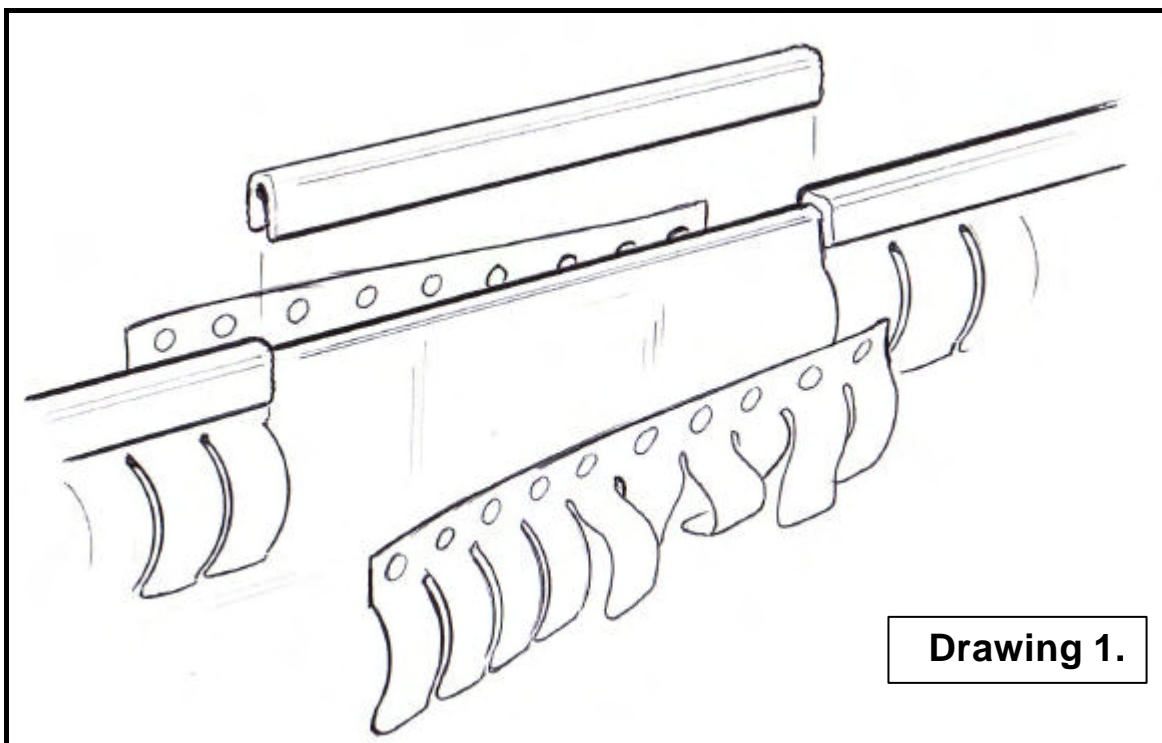

TO FIT NEW FINGERS –

1. Cut aluminium extrusion and copper fingers to correct length. (refer to drawing 2.)
2. Place and hold fingers in the extrusion. (refer to drawing 2.)

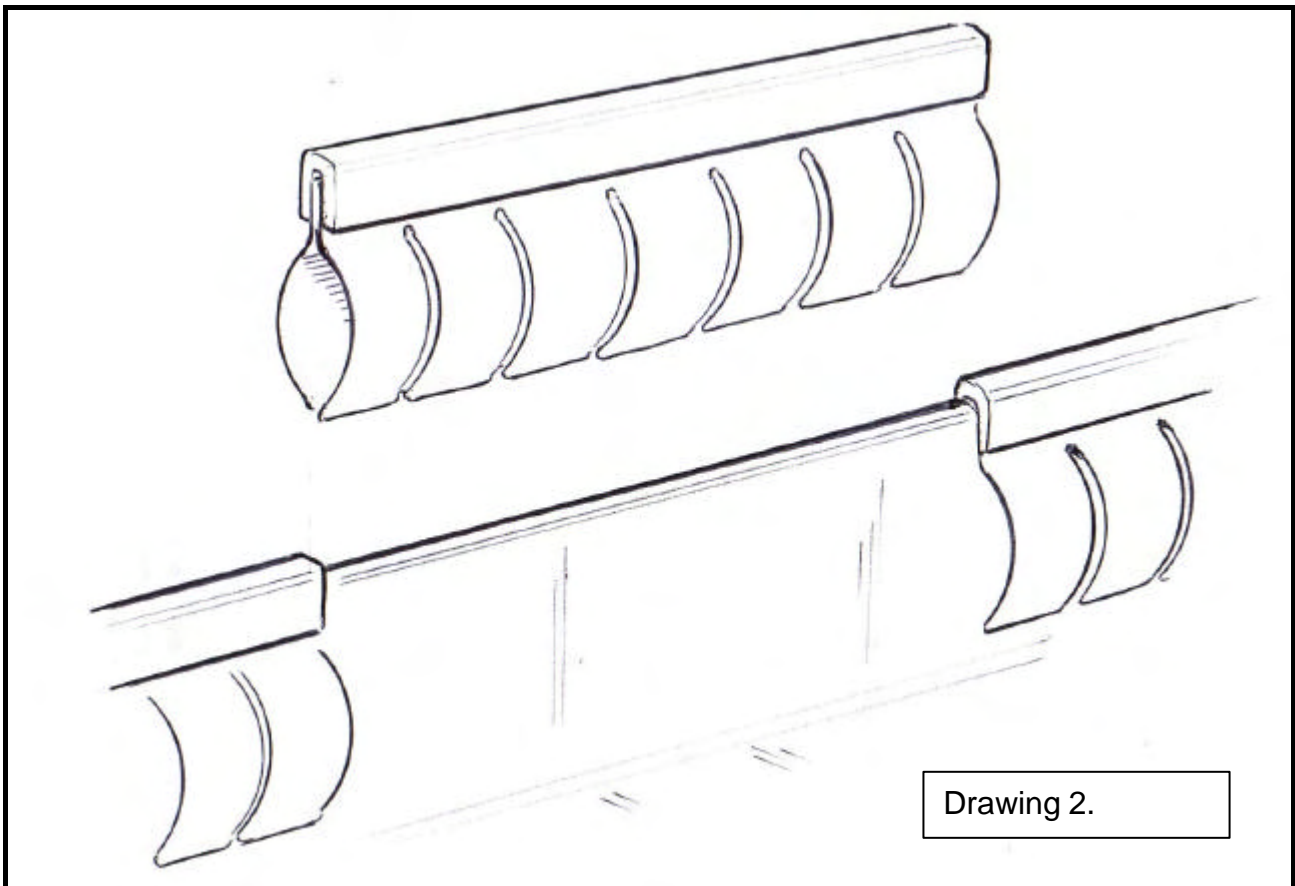

3. Lower assembled extrusion onto door. (refer to drawing 3.)

4. Gently hammer the assembled extrusion into place using a soft head or rubber hammer until firmly in line with existing fingers. (refer to drawing 3.)

